

fatra



Environmental waterproofing solutions

Supply Chain Design Manual



Supply Chain Design Manual

Contents

1.0	INTRODUCTION	2
2.0	FATRA AS	3
3.0	FATRA (UK) LTD	4
4.0	FLAT ROOFING – BASIC CONCEPTS	7
5.0	FATRA ROOFING MEMBRANES	11
6.0	FATRA ROOFING SYSTEMS	15
	6.1 Mechanically fastened – Fatrafol FF810	18
	6.2 Adhered roofing – Fatrafol FF807	20
	6.3 Fatra ballasted or paved roofing system	22
	6.4 Fatra green and brown planted roofing systems	24
	6.5 Fatra replica standing seam roofing system	27
	6.6 Fatra roof refurbishment	28
7.0	ANCILLARY PRODUCTS	29
8.0	DETAILING	33
9.0	ACOUSTICS	41
10.0	SUSTAINABILITY – RENEWABLE/RECYCLABLE PRODUCTS	45
11.0	SUPPLY CHAIN – CONTINUOUS IMPROVEMENT	48

1.0 Introduction

As we look at the legacy of buildings left to us and the modern environment being created, it can be seen that the form and fabric of buildings are an important part of our surroundings. A well designed building can do more than just provide a shelter but also by the informed use of building materials improve the places in which we live and work. This can be brought about by the introduction of surfaces and vistas that create a pleasing aesthetic or because the materials themselves minimise the impact of the building in the environment, both during construction and also when in use.

Fatra has an enviable track record in providing roofing solutions as part of this process. Fatra seek to work with clients on a repeat basis, becoming a respected part of the design and construction team. Our experienced technical staff can assist in all stages of design and construction, from concept and cost-planning through to detailed design and construction. Fatra educates fitters to install the systems correctly, and our site inspection process ensures the roofs are created with minimum defects.

The membranes last more than 30 years without maintenance and come with a full 20 year product guarantee as standard. They can be adapted to almost any roof shape and if required, can accommodate large amounts of insulation to reduce heat loss and improve the acoustics within the building. This is all achieved with sensitivity to the environment by the careful selection of materials and designing the most appropriate roof build up. In the case of the Fatra membranes we also provide for the future by providing recycling resources for when the roof is no longer needed.

This manual is intended as an introduction to what is possible with Fatra. For project specific advice please contact us and see why Fatra is the Future for Building.

Contact us:

Fatra UK Ltd
Unit 12, The Timber Yard, East Moors Road, Ocean Park,
Cardiff CF24 5EE

Tel: 029 2048 7954 Fax: 029 2048 9226

Email: technical@fatra.co.uk

www.fatra.co.uk



2.0 Fatra AS

Fatra is part of the Agrofert Holdings group which has been manufacturing a range of technical foils including waterproofing membranes since 1935. Based in the Czech Republic the group is one of the country's largest employers, with over 20,000 staff and a turnover in 2007 of €130m. Fatra has enjoyed over 75 years of growth and is now one of Europe's largest manufacturers of single ply membranes.

Having held the ISO9001 Quality Standard since 1994 and the ISO14001 Environmental Standard since 2000 Fatra continues to build on a strong foundation of quality, service and a real commitment to the environment.

The latest investment is in a €30m recycling plant. To our knowledge this makes Fatra one of the first manufacturers able to recycle factory waste and site waste back into new waterproofing products.

Fatra membranes contain up to 30% recycled product and provide one of the most durable yet environmentally-friendly roofing solutions available.



3.0 Fatra (UK) Ltd

Fatra was formed over 10 years ago and has been involved in many noteworthy and high-profile projects. The company has continued to expand and now offers one of the most comprehensive packages available in the industry, including a range of high quality components backed by design services, costing advice, field support and training.

Technical support

Fatra's design services include specification, wind load calculation and thermal design.

Additionally, crucial issues such as environmental impact and acoustics can also be addressed using Fatra's extensive experience in these areas.

As well as an ever expanding library of standard details, Fatra's in-house CAD services provide project-specific details where required. All the services are backed by our Professional Indemnity insurance.

Field support

Fatra Field Technicians provide support on site, carrying out quality inspections to ensure correct installation and also advise when details need changing.





Contractors

Fatra work with a range of fully-trained roofing contractors ranging from the largest nationally-known names to smaller regional and local contractors. The individual fitters must be trained at Fatra’s training school and are issued with a photo ID card once qualified.

Guarantees

A completed Fatra roof must be inspected by our Field Technicians before it can qualify for a Fatra Guarantee. Fatra undertake to guarantee all products it supplies; including membranes, fixings and associated components such as trims, rain water outlets, etc. Guarantees can be extended to cover all elements of the roofing system if required.

Quality and environment

Fatra membranes have been fully tested by the leading authorities in the UK. As well as a certified life expectancy of 30 years from the British Board of Agrément (BBA), Fatra also has approvals from Warrington Fire Research (to BS 476 Part 4), Bureau Veritas Certification (both ISO9001 Quality Standard and ISO14001 Environmental Standard), and the Building Research Establishment (Fatra is the only membrane of its type with a ‘Red Book’ listing and Eco-Points score).



For more information on the environmental benefits of using Fatra products please see section 10.0





Mediterranean

fatra



Environmental waterproofing solutions

4.0 **Flat roofing** – basic concepts

4.0 Flat roofing – basic concepts

For a flat roof to perform correctly it must meet with the design guidance as stated in current British and European Standards. This covers amongst other topics – structure, drainage, insulation, fire and access.

Fatra membranes are normally incorporated into warm roofs with the membrane covering a suitable insulation board. Because the insulation board is above the structural deck but below the membrane there is a need to control the vapour transmission through the roof build-up and so a vapour control layer is placed between the insulation and the structural deck. This reduces the amount of vapour transmitted through the roof, and precludes the vapour from condensing on the underside of the membrane which would cause a cold spot and in turn lead to further condensation and ultimately the gradual failure of the roof.

The advantages of this system include the ability to incorporate a fall to the roof and so provide the correct drainage, the thinner insulation used reduces the overall roof build up and the ease with which it accommodates the needs for air tightness.

Structural deck

For single-ply roofing (normally classified as a continuously supported covering) the deck usually consists of one of the following;

Profile metal decks should comply with BS 5950-6 and additionally BS EN 10147 (galvanised steel) and BS EN 485-2 (aluminium). The minimum thickness is 0.7mm for metal and 0.9mm for aluminium.

Wood based panels used as roof decking should as a minimum be either OSB/3 to BSEN 300, type P5 Particleboard to BSEN 312 or Plywood (technical class 'Humid') to BS EN 636. All wood-based panels used as decking must comply with the performance characteristics and marking requirements for wood-based panels used as structural roof decking as specified in BS EN 13986. The thickness must be at least 18mm.

Concrete can either be pre-cast or cast in situ, but in all cases must be finished flat without ridges or nibs that could puncture the vapour control layer. The final finish of the single-ply roof will be affected by the finish of the concrete deck.

Other deck types consisting of composites of the above materials should be assessed by both the designer and Fatra to confirm that they are fit for purpose before any design is completed.



Drainage

There are a number of reasons why a roof should be designed to drain rather than hold standing water. Prime amongst these are the effect of standing water becoming an imposed load on the roof structure potentially leading to damage, and the effect on safe access to the roof due to possible ice build-up and debris collecting on standing water. This can make access to the roof more hazardous than usual.

BS 6229, BS EN 12056-3 and Building Regulations Approved Document H all indicate the need for a roof to drain and in addition BS EN 12056 gives guidance on how to design this drainage through falls in either the structural deck or the insulation.

Insulation

Fatra roofs are normally designed as a warm roof system; this means the insulation is laid above the deck but below the waterproof membrane. Inverted roofs, with the insulation above the membrane, perform less effectively as the insulation is 'wet' and therefore needs a greater thickness to perform correctly. Drainage 'layers' that keep the insulation dry are not effective unless they are installed to a fall and as this increases costs Fatra do not recommend them.

For mechanically fixed roofs the insulation is normally foil faced, for adhered roofs the insulation needs a tissue face to assist the bonding. In all cases the boards must be suitable for use on single-ply roofs.

There are two types of material used to form insulation boards, **foam insulation** typically uses polyisocyanurate foam (PIR) and must be manufactured to BS EN 13165. If **expanded polystyrene** is used it must conform to BS EN 13163 and must have a fleece separation layer between the polystyrene and the Fatra membrane.

Mineral wool boards are the other commonly used insulation; these should comply with BS EN 13162 and be of sufficient density to cope with the proposed traffic over the roof without collapsing. Guidance for the quality of insulation to be used is found in Approved Documents Part L (2006).

Fire

Roof build-ups must be tested to BS 476 Part 3 (soon to be superseded by EN 13501). In the case of Fatra, FF810 can achieve the highest standard of F:AA. Other Fatra roof build-ups achieve different standards and so Fatra's advice should be sought on each individual project.



4.0 Fatra flat roofing – basic concepts

Access

Although Fatra membranes do not need maintenance, the roofs do need maintenance with respect to checking for damage, ensuring that outlets and gutters are draining freely, and other components on the roof, such as roof lights, mechanical plant and green roofing are performing correctly.

Construction Design and Management Regulations (CDM) 1994 and Construction Safety and Welfare Regulations 1966 both state that the designer and the employer have a joint responsibility to provide a safe means of access to the roof. Provision to reduce the risk of falling from the roof can include hand rails or wire fall arrest systems. A Fatra membrane walkway FF812 should be employed as a minimum to provide a well defined, slip resistant surface for maintenance access. For a more durable surface Fatra can advise on a number of options including recycled rubber mats, heavy duty walkways and paving slabs.

Acoustics

For many buildings the control of noise is crucial. BB93 calls for the provision of educational spaces that reduce the intrusion of external noise such as rainfall, traffic and aircraft noise, and also reduce internal reverberation that can reduce the clarity of speech in the class room. The designer should satisfy themselves as to which type of sound control is required and to what extent the roof build-up needs to contribute to the buildings' overall performance.

Concrete decks have intrinsic benefits with respect to the reduction of external noise, however if the deck is metal then the density of the roof build-up will need to be enhanced. This can be achieved through the use of denser insulation or inserting dense acoustic matting into the roof build-up. Fatra can provide design advice on a project specific basis to enable the correct selection to be made in terms of performance, appearance and cost.

When reducing internal reverberation the roof is only one of the surfaces that may be affecting the levels. If an acoustic suspended ceiling is installed then the roof need play no part, but if the soffit is exposed then the metal deck will reflect sound. To reduce this a perforated deck can be used to support the Fatra roof system. The perforations are in the web of the trough and vary in size and quantity. When the trough is filled with a mineral wool batt they reduce the levels of reverberation present. **For more information see Section 9.0.**

fatra



Environmental waterproofing solutions

5.0 Fatra roofing membranes



5.0 Fatra roofing membranes

Fatra manufacture a large range of membranes in a variety of different materials. In the UK there are five main membranes currently in use. Each one is designed for a particular use on a roof, but all are manufactured to the Quality Standard ISO9001 and the Environmental Standard ISO14001, and assessed by Bureau Veritas.

FF810 is a high performance, polyester-mesh reinforced PVC-P roof waterproofing membrane, designed for use as a mechanically fixed waterproofing covering. It is 1.5mm thick giving it improved resistance to damage. The membrane is made from up to 30% recycled materials and at the end of its useful life can be recycled by Fatra into new membranes. FF810 has been assessed by the Building Research Establishment (BRE) and is the only PVC membrane to be listed in the BRE's 'Red Book' and have unique 'Eco-points'. **For more information see Section 12.**

FF807 is a high performance PVC-P roof waterproofing membrane with a non-woven polyester fleece-backing, designed for use as a fully adhered waterproofing covering. It comes in two variants, the 2m wide version has a 0.6mm fleece backing and is for new build projects where the fleece acts to enhance the bond between the membrane and the new insulation board. The 1.3m wide roll is for refurbishment projects where smaller rolls are easier to handle on an existing roof, and the 1.5mm thick fleece assists in bonding to existing substrates or acting as a separation layer over existing felt roofing or asphalt.

FF804 is a non-fleece backed variant of FF807 and is designed as a supplement to Fatra membranes for detail working and finishing e.g. penetrations, vertical abutments etc. It is not suitable for main field area application.

FF812 is designed for use as a slip-resistant walkway. The membrane has a textured surface and is ideal for the demarcation of maintenance routes and should be installed in a contrasting colour to the main field area. It is also used as the waterproofing liner for the Fatra range of gutters.



fatra



Environmental waterproofing solutions

6.0 Fatra roofing systems



6.0 Fatra roofing systems

In single ply roof design there are a number of factors that can influence the choice of single ply roofing system. For this reason the first point of contact should be the Fatra Regional Sales Manager who can advise not only on the most suitable products and build up but also provide the details of installers who will give best value for your specific project.

The key requirement is to provide a cost effective waterproofing system and so Fatra's first aim is always to ensure that the roof is suitable for a Fatra system. Following that, consideration must be given to the internal use, requirements to control sound (either attenuation or reverberation) and this is considered in conjunction with the structural deck, the size of the project and its location. The finish must then be considered and whether the roof is to be trafficked or used as an amenity.



Mechanically fixed

Fatra mechanically fixed roofs are typically used on structural decks formed from metal or plywood, or in high wind load areas.



Fully adhered

When the deck is concrete, or the building has high humidity, bonding is the preferred option.



Green and brown roofs

The planted finish can be varied from a sedum 'turf' through landscaped areas or can be bio-diverse to encourage local flora and fauna.



Replicating standing seam roofing

Traditional standing seam roofing can be costly and difficult to install on roofs with complex shapes. Fatra membranes provide a suitable base to install Fatra Standing Seam Profiles at centres to replicate a metal finish.



Reroofing existing buildings

It is important to carry out a thorough investigation of the existing roof before being able to confidently select an appropriate system.

6.0 Fatra roofing systems

6.1 Mechanically fastened – Fatrafol FF810

The Fatra mechanically fastened system uses Fatrafix fixings to hold a loose vapour control layer and a choice of rigid insulation boards laid over the structural profiled metal or plywood deck. The layout and density of the fixings is dictated by the wind load characteristics of the site.

The Fatrafol FF810 membrane is then bonded to the Fatra discs using Fatra FF855 adhesive. The sheets of FF810 are then welded together using hot air welding to provide a waterproof finish. The method of attachment results in the membrane being held at regularly spaced centres which does not allow excessive movement and enhances the appearance of the completed roof. The system is adaptable to most roof shapes and deck types.

Quick to install, the complete roof also holds a unique Eco-Points assessment from the Building Research Establishment and is listed on the BRE's 'Red Book Live' website.

The membrane can be removed at the end of its useful life and recycled.

Illustration: Mechanically fastened – Fatrafol FF810

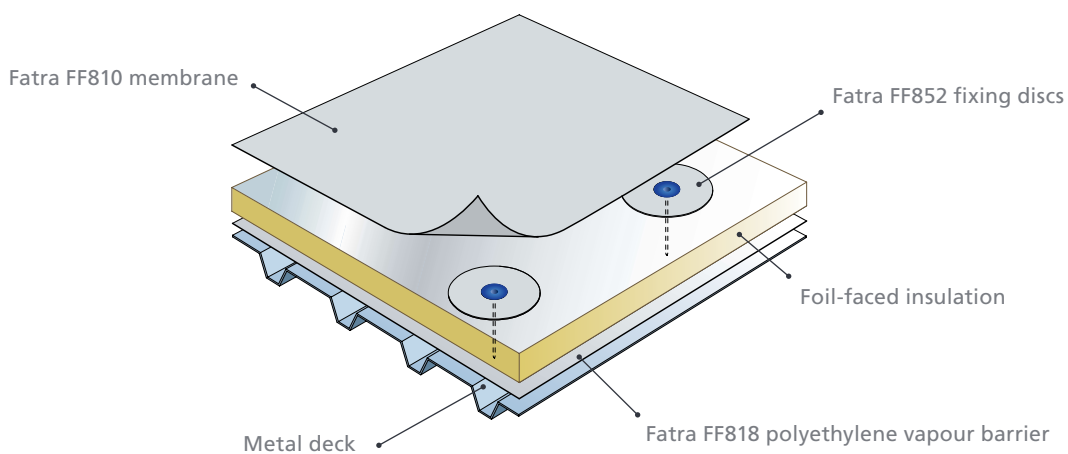

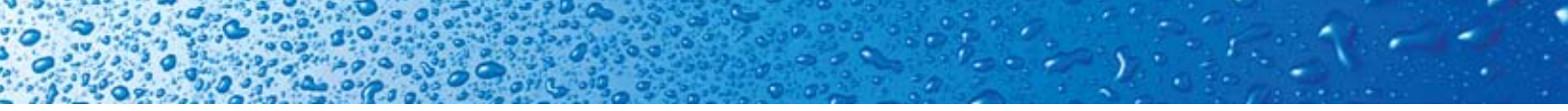

6.1 Mechanically fastened projects



6.0 Fatra roofing systems

6.2 Adhered roofing – Fatrafol FF807

In a Fatra fully-bonded roof each layer is bonded to the next giving a better finish in addition to avoiding the need for fixings.

The Fatrafol FF816 self-adhering felt vapour control layer is bonded to the deck and provides a temporary waterproof surface that can be used as a working platform when required. The tissue faced insulation is in turn bonded to the vapour control layer's upper face and the Fatra FF807 bonded to the insulation using FF859 adhesive.

The completed roof gives a pleasing finish and is often used when appearance is important. Alternatively the FF807 roof can be covered in ballast and paving slabs (see Section 6.3), green or brown planted roofs (see Section 6.4) or can replicate standing seam roofing using Fatra Profiles (see Section 6.5).

Illustration: Fully adhered – Fatrafol FF807

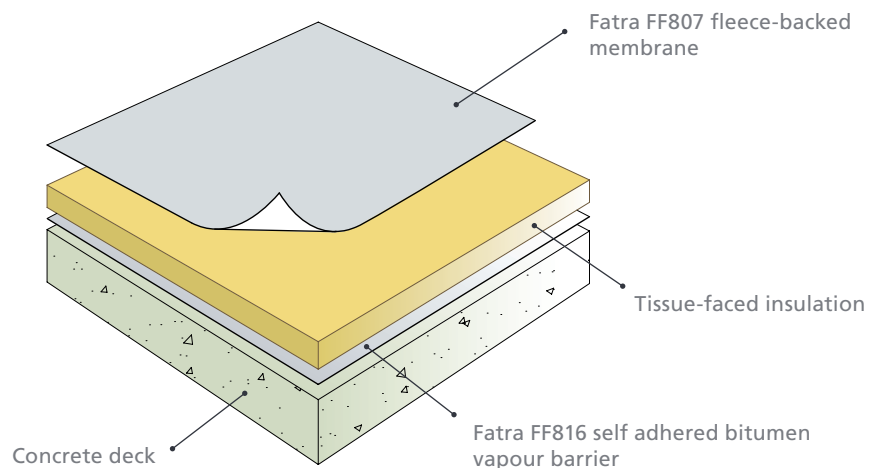



6.2 Adhered roofing projects



6.0 Fatra roofing systems

6.3 Fatra ballasted or paved roofing system

The introduction of paving, ballast or a timber deck can transform a Fatra roof into additional floor space for use as a recreational space, residential balcony or an amenity for staff.

A Fatra bonded roof is covered with an additional protective sheet and then, depending on the final finish required, either a series of paving slabs are laid on Fatra FF865 Support Feet, a timber deck is installed, or as a decorative perimeter to the other options (or as a finish in itself) a layer of rounded ballast (20-40mm, washed) is spread.

Illustration: Ballasted or paved roof system

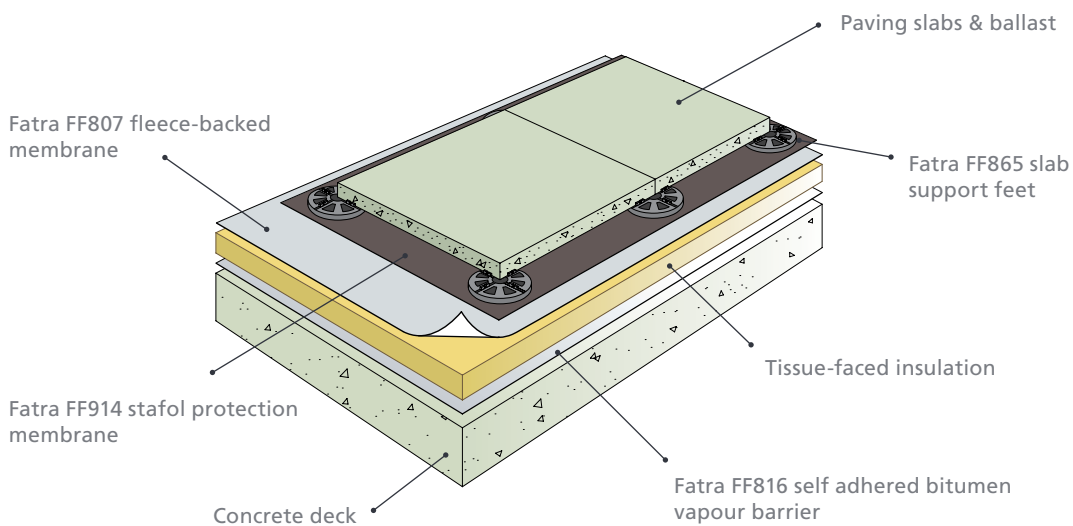



6.3 Fatra ballasted or paved roofing projects



6.0 Fatra roofing systems

6.4 Fatra green and brown planted roofing systems

It has long been recognised that introducing green space can improve the local environment. This effect not only includes the reduction of the urban heat island effect and the introduction of flora and fauna into a locality but recent studies have also indicated reduced times for healing for hospital patients and increased concentration for office staff and students.

Fatra's green roof systems offer the option of providing green spaces in unexpected areas. Not limited to small plants, but if the correct vegetation and landscaping is selected, providing habitats for invertebrates such as spiders and ladybirds, which in turn encourages the local bird population.

A landscaped roof provides an amenity space for the building's occupiers and makes clever use of the available space as well as promoting a positive image of the building's owners and occupiers.

Illustration: Green roof build-up

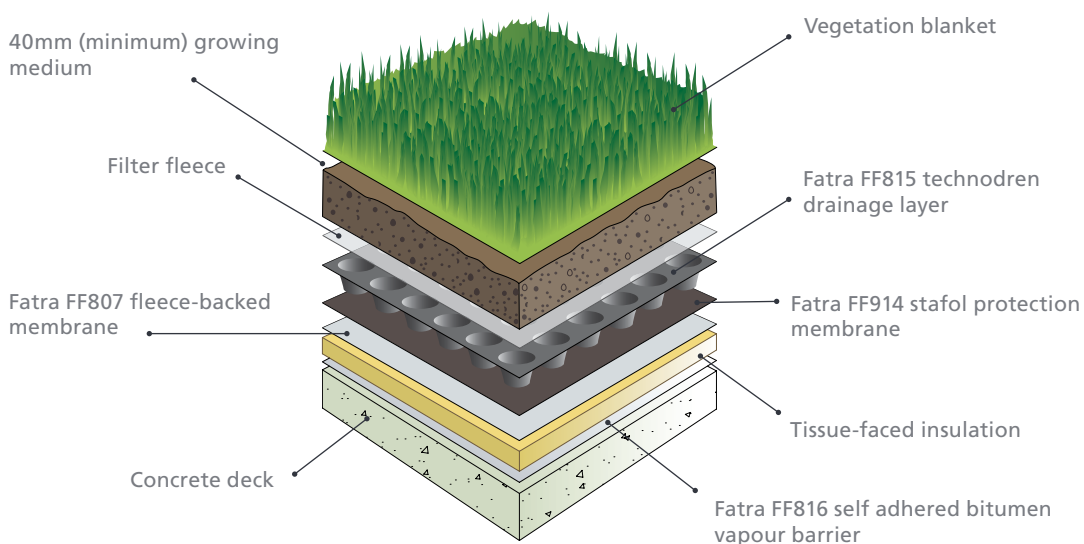
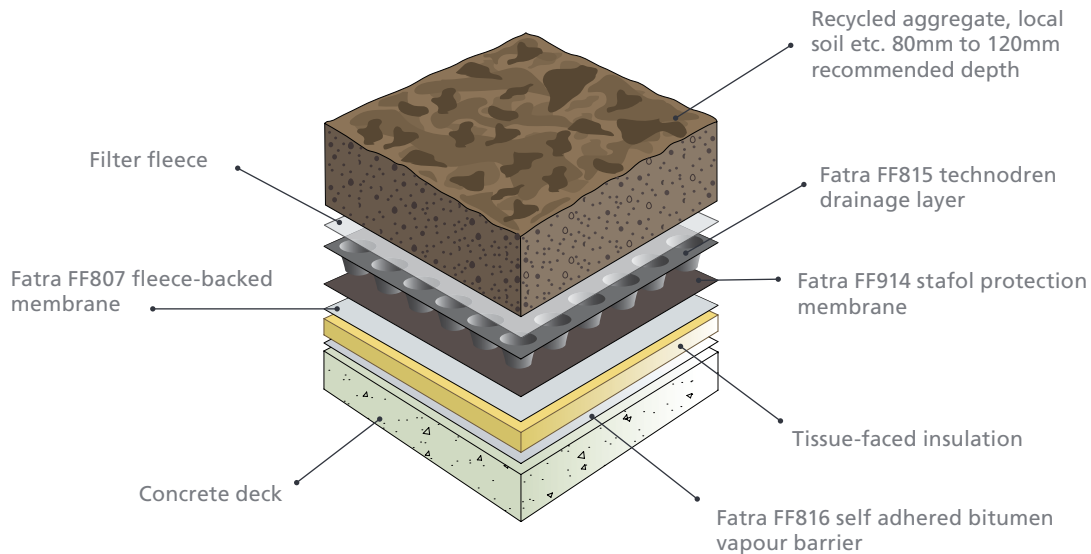



Illustration: Brown roof build-up



Fatra green roof systems are laid on a bonded Fatra roof. A Fatra Technodren drainage layer is laid over a protective fleece and then covered with a filter layer. The green roof that follows can consist of a mixture of reclaimed site waste and small hardy plants, or can be planted out with sedums, or even small bushes. To ensure that each roof performs as expected Fatra has partnered with a number of green roofing experts to provide detailed design advice and installation services.

A Fatra green roof can also reduce water runoff and so form part of a SUDS solution. The green finish also reduces the urban heat island effect that causes so many asphalted areas to become hot in the summer, and thereby improve the learning environment for occupants.

6.0 Fatra roofing systems

6.4 Fatra green and brown planted roofing projects



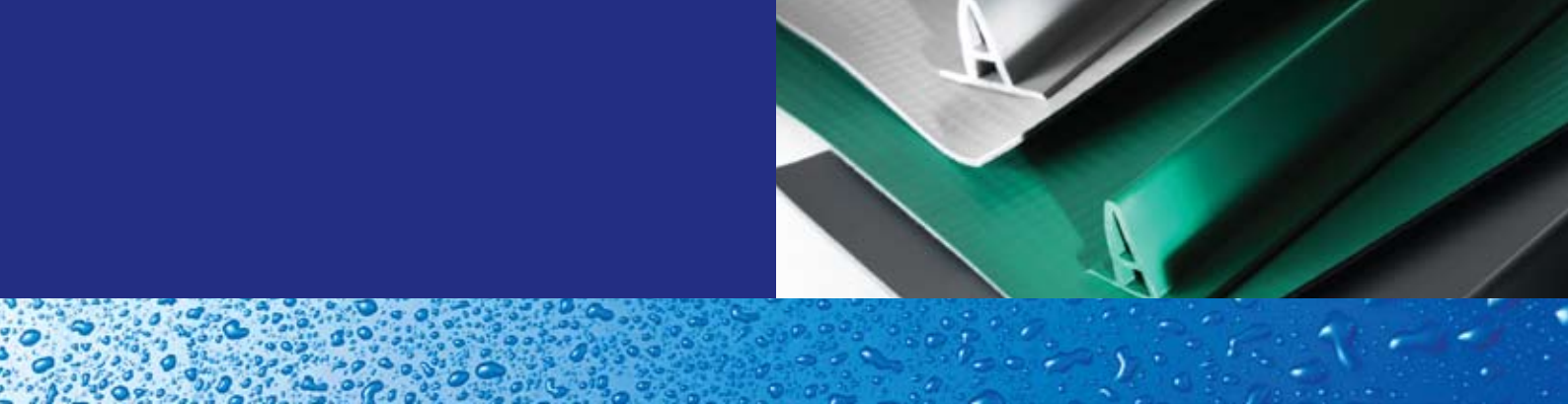

6.5 Fatra replica standing seam roofing system

With the increase in insulation values and raw material prices metal standing seam roofs have become increasingly expensive. The Fatra Standing Seam Profile offers the designer the opportunity to preserve the aesthetic of standing seams whilst reducing costs.

A Fatra FF814 profile is welded to the completed Fatra bonded roof, imitating the visual effect of a metal roof but without the inherent costs and on-site welding often associated with standing seam roofing.

Various colours are available to increase the effect.

Illustration: Replica standing seam roofing system

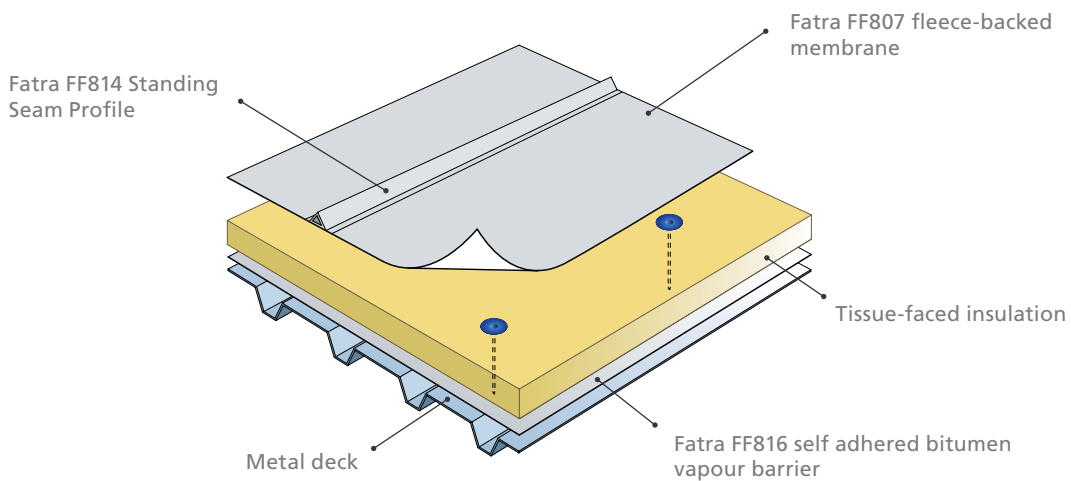



6.0 Fatra roofing systems

6.6 Fatra roof refurbishment

To construct a new building is not always a cost-effective or environmentally sensitive approach. Fatra products make refurbishment of older buildings a viable alternative to new construction.

As long as the structural deck has not been compromised the option of re-roofing an existing building with Fatra products can be considered.

A detailed survey should be carried out to ascertain whether the existing roof coverings have deteriorated to the extent that they must be stripped off, or if it is possible to overlay the existing roof. Overlaying carries the possibility of reducing the disruption to the building's occupants, allowing the work to be carried out while the school is in operation. For a detailed assessment Fatra should be called in to provide a roof condition survey and report on the options most suitable for each project.



fatra



Environmental waterproofing solutions

7.0 Ancillary products

7.0 Ancillary products

Fatra's aim is to provide a complete roofing solution. As part of this Fatra has introduced a number of components to ensure that the rest of the roof performs to the same high standard as the membranes. This also introduces the option of having a complete system guarantee covering all components on the roof.

Rainwater outlets

Due to the amount of water that flows over them outlets are often the items that cause the most problems on a roof. Fatra provide a wide range of outlets, engineered to meet modern roofing design standards and are fully compatible with Fatra membranes. They enable the outlet to be welded directly to the membrane and so remove the need for mastic seals and clamping rings – both items that commonly fail on traditional roofs.

Fixings

By supplying a range of fixings specifically selected to meet the needs of the Fatra mechanically fastened system Fatra provides durable and cost effective components that ensure the roof is reliably secured in place. As part of this service Fatra also provide windload calculations to ensure the correct fixing density is used.

Insulation

Where a system guarantee is required Fatra have partnered with the leading manufacturers of insulation. This enables Fatra to offer a selection of insulants that meet the requirements of any given project. Thermal calculations can be provided to ensure correct thicknesses are used. Cut to falls schemes can be arranged where drainage is an issue.

Roof lights

The provision of daylight into a building can provide many significant benefits. Fatra are working together with roof light manufacturers to provide a number of creative solutions from simple domed or pyramided lights to complete barrel vaults and structural units.

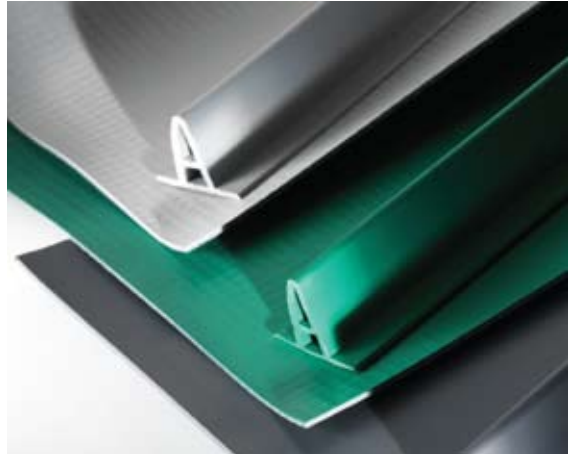

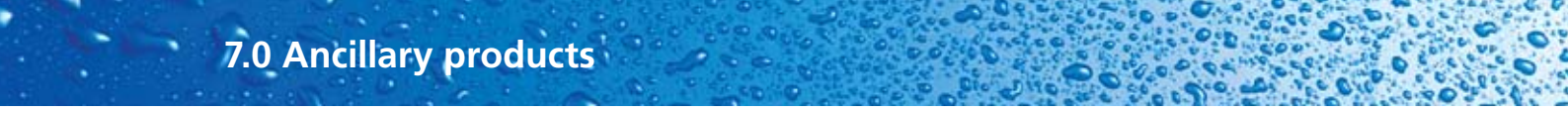

7.0 Ancillary products

Gutters

Fatra lined gutters have been used on some of the most prestigious projects in the country including Wembley Stadium and Wimbledon Centre Court.

The gutters are manufactured in the UK using specially formulated membrane from the Fatra factory. The membrane has a textured finish the same as the Fatrafol FF812 walkway membrane and this provides a slip resistant surface that is safer to walk on but does not impede the flow of water in the gutter.

The textured membrane is laminated onto hot dip galvanized steel which has additional epoxy coatings to provide a durable finish. This can then be formed into a single skin gutter used for un-insulated roofs or when overlaying an existing roof build up, or can be incorporated onto an insulated composite gutter using a range of suitable insulants.

The finished gutter can be welded to a Fatra membrane roof finish providing a jointless finish without the problems caused by interfaces, or it is often used on metal roofing.

For both roof types the gutter sections are joined using the same hot air welding technique as used on Fatra roofs, this avoids the failed jointing that was the case in traditional gutter systems.

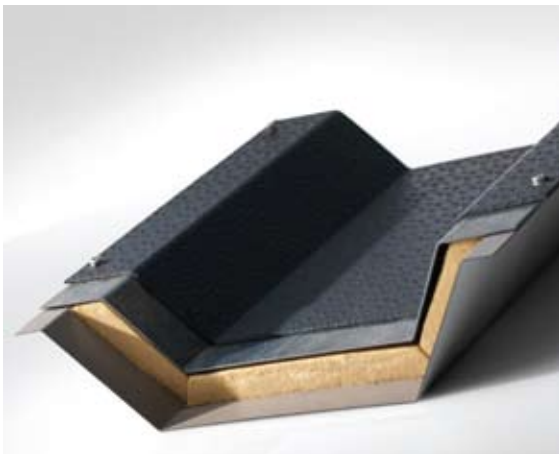

fatra



Environmental waterproofing solutions

8.0 Detailing



8.0 Detailing

Details must follow the standard guidance in BS6229: 1982 Code of Practice for Flat Roofs. However to assist the designer Fatra are able to produce project-specific design advice including AutoCAD and on-site support when required.

The detailing and finishing of Fatra roofs are achieved through the use of prefabricated components. Fatra works with a UK based manufacturer who laminates specially selected Fatra membranes on to a range of galvanised metals. These laminated metal strips are used at every change in direction or termination of the roofing system. This use of metal components gives a Fatra roof precise detailing and avoids the membrane 'tenting' across different planes. The resulting smooth finish provides a better surface for rainwater to flow over into rainwater outlets and gutters.

Corners are sealed using pre-formed pieces of membrane thus avoiding poorly formed details with folded membranes not correctly welded in place.

This use of preformed and prefabricated components reduces the risk of defects as well as reducing time on site. The completed Fatra roof has crisp detailing with secured terminations and finishes that are easily checked by the roofing contractors' staff as well as the Fatra Field Technician.

The installation of Fatra details is a skilled process and the fitters are trained at the Fatra Training School in the correct process of installation and the selection of the appropriate components.

To ensure the correct design the relevant Fatra Regional Sales Manager should be contacted who can provide project specific advice as well as confirming the most cost-effective way of waterproofing the roof.

Upstands on mechanically fastened roofs

A length of Fatrametal is used to pin the FF810 field sheet into place at the base of the upstand. Fixings should be at 200mm centres and fixed into either the deck or the upstand – whichever is more practical.

The top of the upstand is also covered with a Fatrametal angle – and this detail can be continued to the external edge of the parapet if desired. Alternatives include a 'Z' cleat of Fatrametal to take the membrane behind a cladding detail or a flat bar termination metal if a render system is being used above the Fatra membrane.

8.0 Detailing

The upstand is then dressed in either FF804 or FF810 membrane. However it should be noted that upstands should be at least 150mm above the finished surface of the roof.

The detailing membrane is dressed down the side of the upstand, if the distance between the roof and the top of the flashing is over 600mm then a FF861 contact adhesive is used to bond the membrane to the parapet. For upstands over 1200mm the Fatra mechanically fixed system can be adapted using the fixings and discs on the internal face of the parapet to hold the insulation in place before fixing the FF810 membrane into place. It should be noted that although this provides a waterproof solution it will not normally be an aesthetic finish.

At the base the membrane is dressed into the fold of the Fatrametal angle and welded using a 'penny roller', it is then dressed across the edge of the Fatrametal and on to the main roofing sheet and is welded in place.

Illustration: Mechanically fixed parapet and corner detail

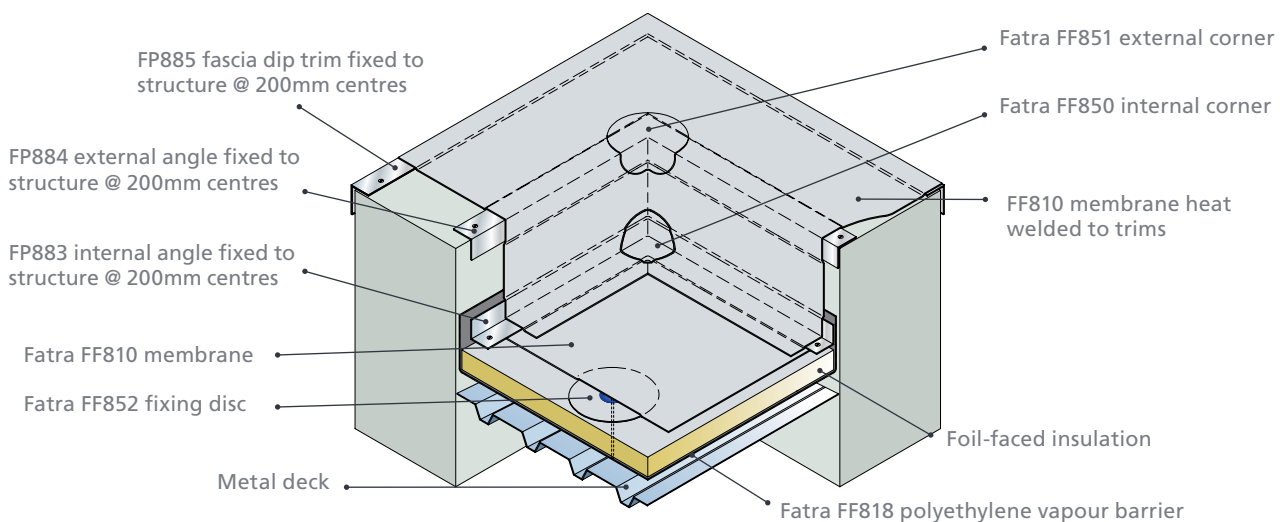



Eaves details mechanically fastened roofs

When a flush eaves detail is required the Fatrametal drip edge trim is fixed at 200mm centres and the FF810 field membrane is welded to the top face of the trim. This detail is faster and more cost effective when compared to most systems. When this detail is utilised the Fatra fixing discs should be close to the perimeter of the roof.

Illustration: Mechanically fixed eaves detail

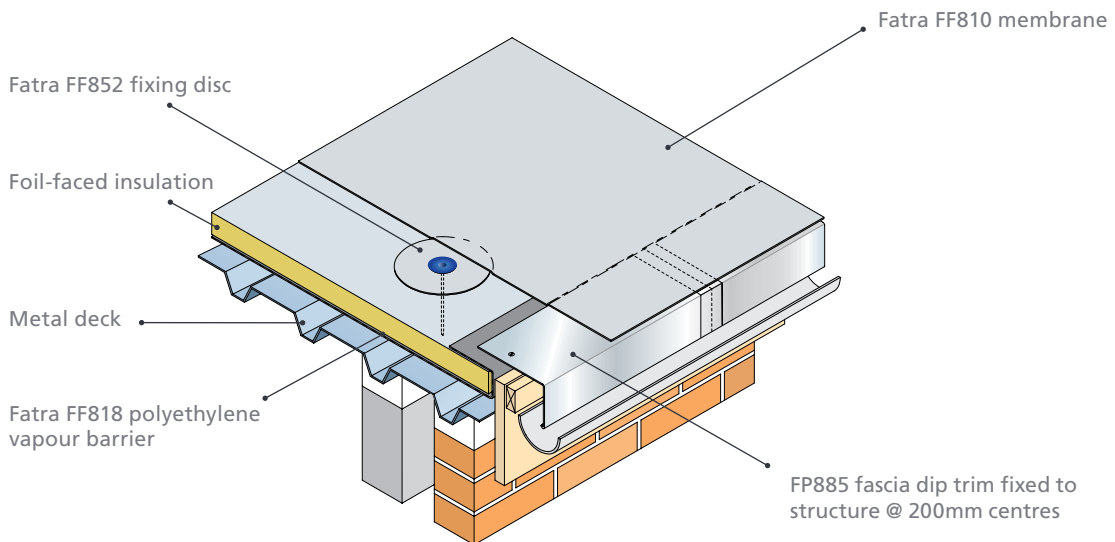

8.0 Detailing

Upstands on adhered roofs

A length of Fatrametal is used to pin the FF807 field sheet into place at the base of the upstand. Fixings should be at 200mm centres and fixed into either the deck or the upstand – whichever is more practical.

The top of the upstand is covered with a Fatrametal angle also – and this detail can be continued to the external edge of the parapet if desired. Alternatives include a 'Z' cleat of Fatrametal to take the membrane behind a cladding detail or a flat bar termination metal if a render system is being used above the Fatra membrane.

The upstand is then dressed in FF804. The detailing membrane is dressed down the side of the upstand, if the distance between the roof and the top of the flashing is over 600mm then a FF861 contact adhesive is used to bond the membrane to the parapet.

However it should be noted that upstands should be at least 150mm above the finished surface of the roof.

At the base the membrane is dressed into the fold of the Fatrametal angle and welded using a 'penny roller', it is then dressed across the edge of the Fatrametal and on to the main roofing sheet and is welded in place.

Illustration: Fully adhered parapet and corner detail

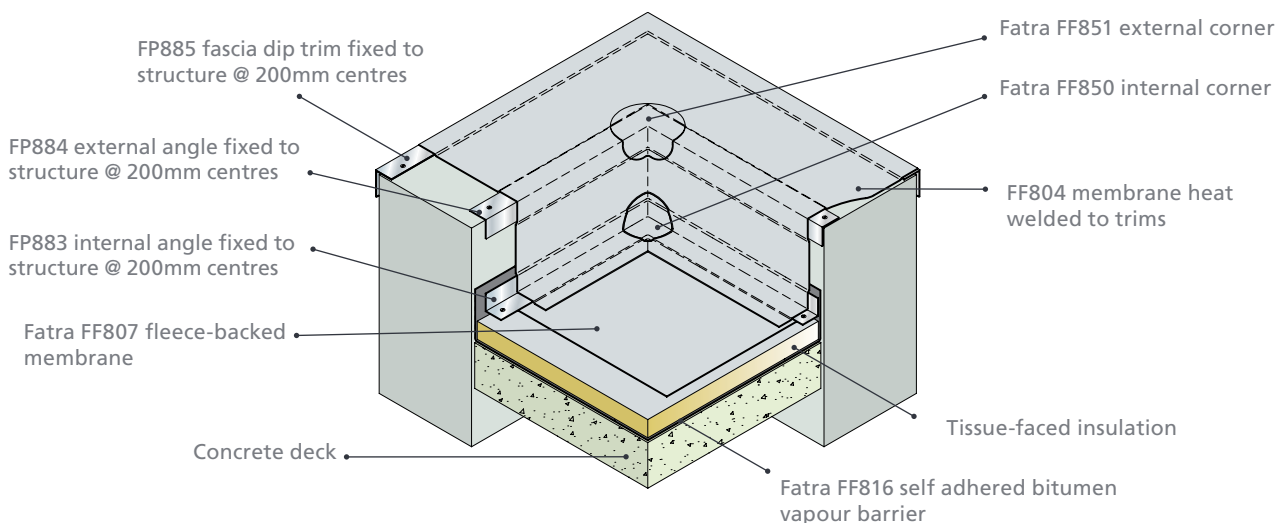



Eaves details adhered roofs

When a flush eaves detail is required the FF807 field membrane can be trapped under the Fatrametal drip edge trim which is then fixed at 200mm centres. The eaves are then completed by welding a cover flashing of FF804 over from the field sheet to the edge of the Fatra metal trim.

Illustration: Fully adhered eaves detail

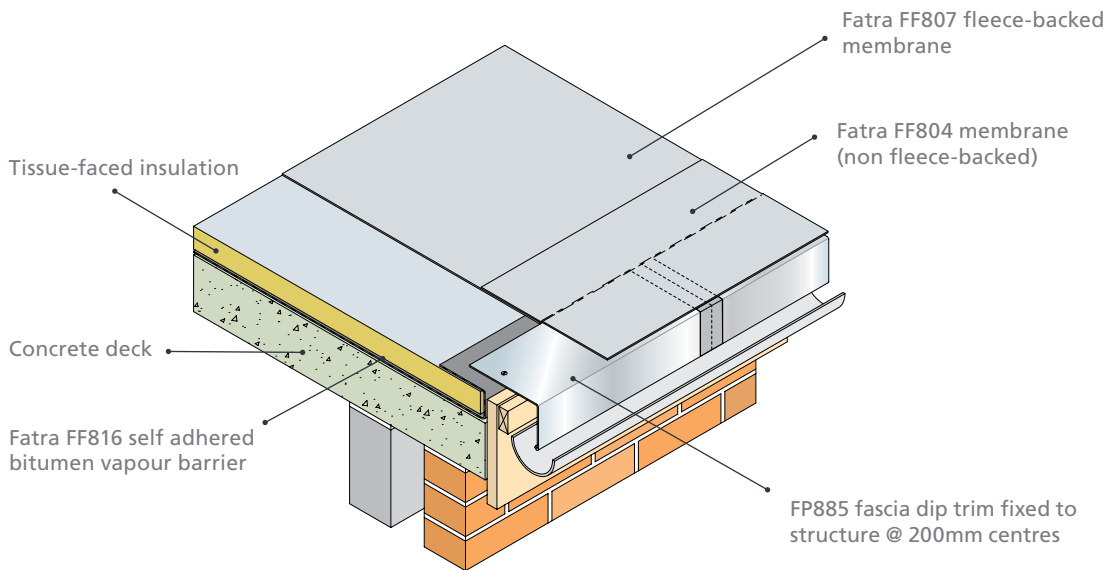



8.0 Detailing

Penetrations

For pipe penetrations (which include stub columns, struts, handrails, etc.) the first requirement is that a round hollow type section should be selected wherever possible, 'I' beams and flat plates are difficult to detail in membranes. The main field sheet is stopped around the penetration and a sheet of FF804 is dressed around the pipe to a height of not less than 150mm and held in place with a stainless steel 'band clamp'. The flashing is splayed out and welded to the base sheet which in turn is welded to the field sheet.

Rain water outlets are provided by Fatra. The insulation around the outlet should be recessed slightly to avoid water ponding around the outlet and once the outlet is in place it should be welded to the main field sheet with the flange of membrane that is laminated to the outlet.

Illustration: Fatra FO range roof outlet and pipe penetration

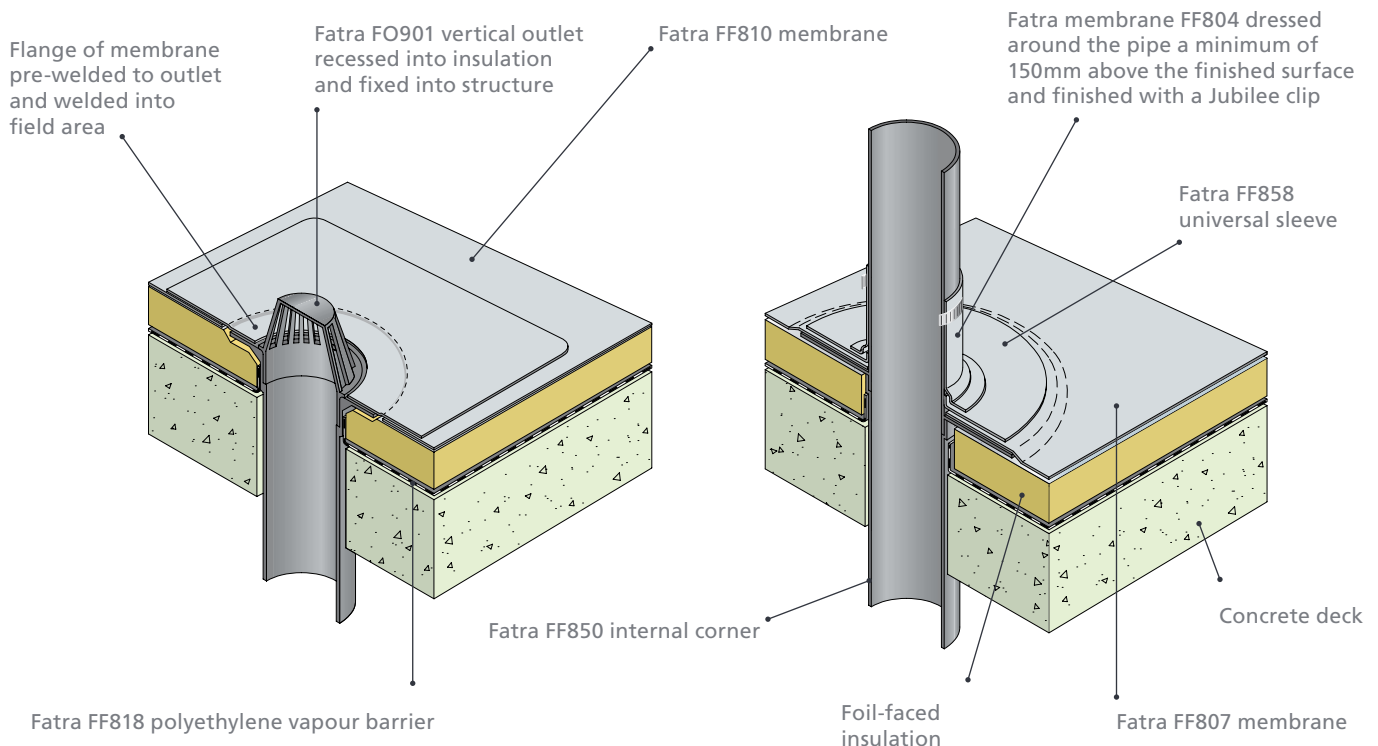

fatra



Environmental waterproofing solutions

9.0 Acoustics

9.0 Acoustics

General

The impact of noise in a building falls into two distinctive types, reverberation is noise generated internally and reflected off the internal surfaces of the building – either the walls, floor and ceiling or the furnishings; attenuation which is the noise intruding into the building either from man-made sources such as planes or traffic or natural such as rain noise. For education buildings the guidance is covered in BB93 'Ambient Noise Levels' and the DCSF Document 'Standard Specifications, Layouts and Dimensions – Roof Covering in Schools'.

Specific advice should be sought from Fatra for each individual project. Fatra will then work with Rockwool and other partner suppliers to provide a calculation of acoustic performance using software developed with the Building Research Establishment. However, Fatra advise that an acoustician is included in the design team at an early stage to fully address these issues.

In either situation the selection of materials to improve acoustic performance can affect the choice of Fatra system used to waterproof the structure. Additional mass can increase the quantity of insulation and adversely affect cost – especially if there is a cut to falls insulation scheme required. Reducing sound reverberation using perforated decks can affect structural performance as well as aesthetics.



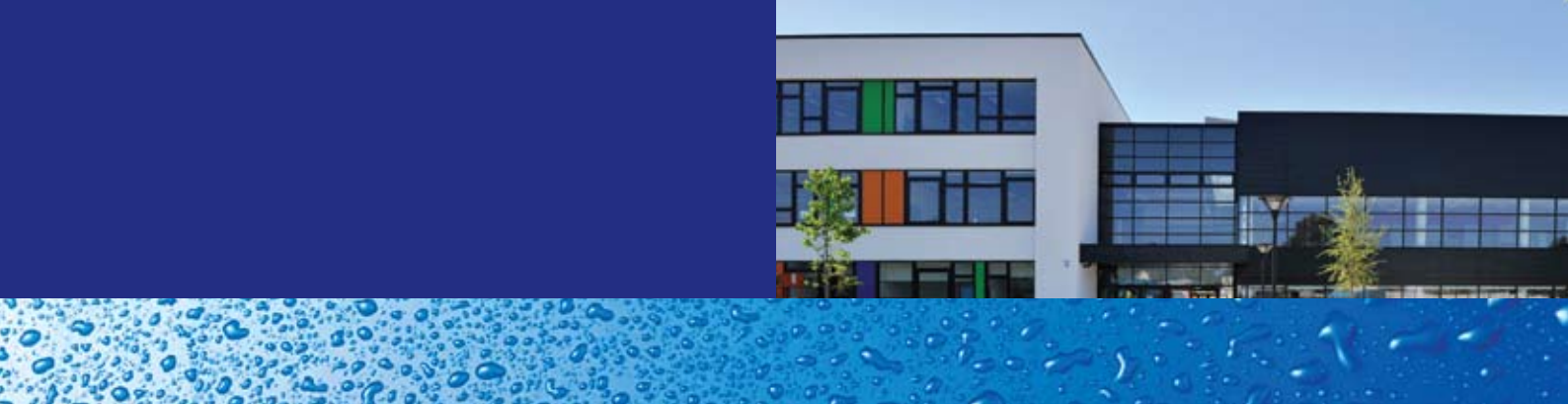

External noise

If there is a requirement to reduce sounds produced by external sources, either man-made such as traffic, industry or aircraft, or natural such as rainfall, these can be addressed by the selection of the correct Fatra Roof System.

When the structural deck is concrete or if a 'green roof' system is selected then it is unlikely that there will be any need for further measures to reduce sound penetrating the roof as there will be enough sound absorbing materials in the roof build-up. However, if the roof is a lightweight construction, i.e. on a metal structural deck, then additional material may need to be introduced into the roof build-up to reduce sound intrusion.

Fatra work with Rockwool and others to provide a number of solutions that can provide different sound reduction characteristics depending on the particular requirements of the building in question. Typically these will consist of using 'Hardrock' mineral wool insulation, sometimes with the introduction of a 'sound reduction' mat to increase the acoustic mass of the roof build-up.

When additional materials are used to increase the absorbency of the roof build-up it can lead to a significant increase in cost – especially if a cut to falls insulation scheme is envisaged.

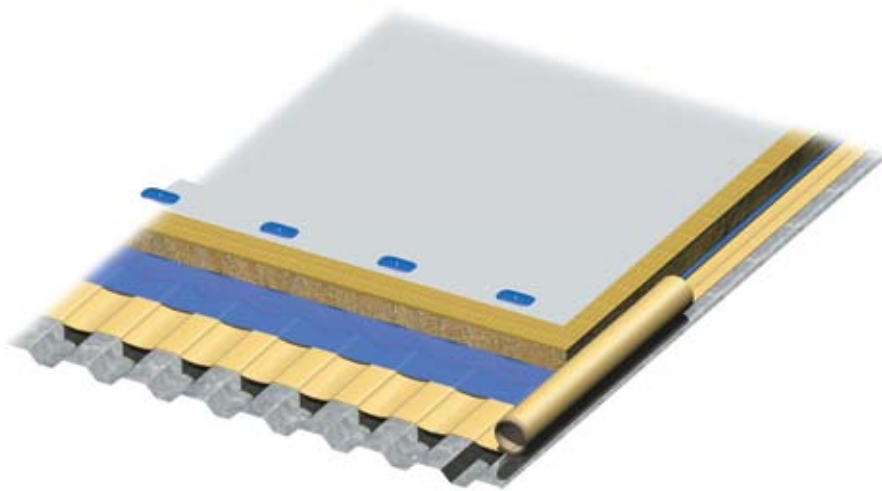

ROCKWOOL®

 **FATRAFOL**



9.0 Acoustics

Internal reverberation

Reducing internal reverberation can affect roofing design in areas where there is a preference to avoid the use of ceiling tiles – either to reduce cost or because the room use does not lend itself to a fragile ceiling finish – such as in a sports hall or drama space.

In these situations, and when the deck is structural metal, the underside of the deck can reflect a significant amount of sound. Introducing a perforated deck and filling the troughs with a sound absorbing material such as Rockwool Acoustic Infill can be part of the design strategy, although allowances should be made for the reduction in the decks' spanning capability.

In addition, consideration should be given to the aesthetic effect of having an exposed soffit and the possibility of fixings showing through.

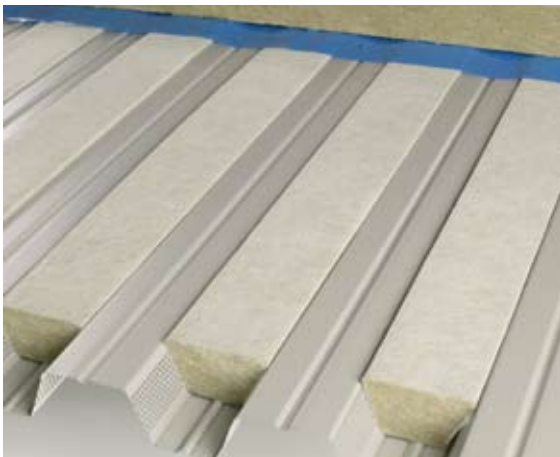

fatra



Environmental waterproofing solutions

10.0 Sustainability

10.0 Sustainability – renewable/recyclable products

No modern manufacturer can ignore the affect of its activities on the environment. Fatra prides itself on its commitment to quality and the environment and has held ISO14001 since 2000, assessed by Lloyd's Register Quality Assurance Limited. Fatra is, to our knowledge, one of only a few single-ply manufacturers to have ISO14001 for the manufacture of their products rather than just for their office functions.

In addition, many clients have carried out their own independent assessment of Fatra's environmental approach and have been impressed by their findings.

Extensive research has been carried out to ensure that Fatra maintains its lead in technology. The company's R&D department is highly valued and carries out work for other manufacturers as well as assessing products for companies such as Kimberly Clarke and IKEA. The factory has recently invested €30M in a factory based recycling plant. This makes Fatra the first roofing manufacturer in Europe to be able to recycle not only factory waste but also site waste into new waterproofing material. Recent advances have meant that Fatra are now able to include up to 50% recycle in new roofing membranes.

In 2008 the Building Research Establishment published the 'New Green Guide to Specification' (www.thegreenguide.org.uk). This now states that PVC membranes such as Fatrafol can achieve an A+ rating, the most environmentally friendly rating possible.





At Fatra we have undertaken further assessments with the Building Research Establishment and have now been awarded our own Environmental Profile and a listing in the BRE's Red Book under Environmental Assessment. We are now the most environmentally efficient company within our sector with a BRE Eco-Point score of 0.4. This enables building designers working to the BRE environmental assessment method (BREEAM) and associated BREEAM for Schools and EcoHomes to use this unique score to achieve the desired environmental profile for the project. This 'cradle to grave' 60 year study has awarded Fatra with an A+ Rating.

Environmental Profiles measure environmental performance throughout a product's life:

- In manufacture (including impacts from virgin and recycled inputs)
- In use in a building (taken over a typical building life and including maintenance and replacement)
- In demolition (the waste produced, allowing for recycling and reuse)

Environmental Profiles provide key indicators of environmental sustainability for:

- Climate change – from CO2 and other greenhouse gases especially associated with energy use
- Ozone depletion – from gases affecting the ozone layer
- Acidification – from acid gases reacting with rain (acid rain) or water in the soil
- Consumption of minerals and water
- Emission of pollutants to air and water – including toxicity to humans and ecosystems
- Quantity of waste sent to disposal

When these environmental assessments are combined with the 30 year life expectancy given by the BBA we believe this makes Fatra one of the most environmentally friendly roofing materials available today.



fatra



11.0 **Supply chains –**
continuous improvement

11.0 Supply chains – continuous improvement

As can be seen from this manual Fatra have had considerable experience in providing the support needed at design stage and during construction to ensure successful outcomes to roofing projects. Many clients have taken advantage of this level of support and have engaged Fatra's services at the early stage of their projects to ensure that initial decisions are made on the basis of the correct roof design.

The benefits of using Fatra as part of an integrated supply chain include:

- Increased efficiencies by Fatra supporting your operational procurement and technical staff at all times
- Fatra's continual innovation to provide clients with the most up to date technical information based on the latest innovative products to ensure the maximum value engineering opportunities are utilised
- Intensive support to both the design and site staff to enable all to provide the highest quality roofs on time and within budget
- Fatra's aim of developing and overseeing partnership relationships between the sub contract supply chain and clients
- Fatra inspections of completed projects to confirm that they have been installed to our high standards

By engaging with our clients at this level of detail Fatra are able to offer market leading levels of quality backed by guarantees that are tailored to specific requirements. But we do not stop there, as building technology becomes ever more complex and our clients look for greater efficiencies and increased quality Fatra will continue to learn from our current projects and work to satisfy our customers.

Acknowledgements

CABE/Dave Morris

Skanska UK plc

Evergreen Roof Gardens Ltd

fatra



Environmental waterproofing solutions

Unit 12, The Timber Yard, East Moors Road, Ocean Park, Cardiff CF24 5EE
tel: 029 2048 7954 fax: 029 2048 9226 email: sales@fatra.co.uk
www.fatra.co.uk

Fatra UK Limited is registered in Wales. Company Registration No: 3334094
Printed with vegetable-based inks on recycled paper, FSC certified.
Design by Dandi Creative www.dandicreative.co.uk