

PROTEC EVOLVE SYSTEM WARM ROOF NEW BUILD

(ADHESIVELY BONDED INSULATION WITH CARRIER LAYER)

OUTLINE SPECIFICATION / NBS CLAUSES

Ref: PP20304
Version: 3.1



POLYROOF
ADVANCED LIQUID ROOFING

Part of
**Roberts
Group**

PROTEC EVOLVE SYSTEM WARM ROOF NEW BUILD (POLYROOF SA CARRIER LAYER) GUIDANCE DOCUMENT

Polyroof.co.uk
0800 801 890

1	Introduction	3
2	Specification Summary.....	4
2.1	Construction A – Timber Joists.....	4
2.2	Construction B – Concrete Decks.....	6
2.3	Construction C – Structural Metal Roof Decks.....	8
2.4	Warm Roof Components.....	10
2.5	Protec Evolve Application.....	13
2.6	Roof Details.....	16
3	NBS Clauses (Uniclass).....	17
4	Health & Safety	19
4.1	Personal Protective Equipment (PPE).....	19
4.2	Material Safety Data Sheets (MSDS).....	19
4.3	Risk Assessments / Method Statements.....	19
4.4	VOC / Odour Control.....	19
4.5	VOC Measuring.....	20
5	Further Information.....	21
5.1	Warm Roof Components.....	21
5.2	Further Reading.....	21

This document is a guide to assist in the production of tender documents. It is the responsibility of the client to add and delete clauses as relevant to the contract. Nothing in this proposal or any other literature produced by or on behalf of Polyroof Products Ltd is to be regarded as constituting a contract binding in law between Polyroof Products Ltd and any customer. The only contract which Polyroof will enter into is that contained in the Polyroof guarantee which takes effect only when issued in writing by Polyroof to the customer. Specimen guarantees are available on request.

PROTEC EVOLVE SYSTEM WARM ROOF NEW BUILD (POLYROOF SA CARRIER LAYER) GUIDANCE DOCUMENT

Polyroof.co.uk
0800 801 890

1 Introduction

The following outline specifications are based on application of the advanced low-odour Protec Evolve System to Polyroof SA Carrier Layer installed over Polyroof Tissue-Therm Insulation. The specifications are for use on either timber joists, concrete decks, or structural metal roof decks.

Please note that these outline specifications are based on preliminary discussions only. We welcome the opportunity to discuss your project further to finalise a proposal that is tailored to your exact requirements.

This system is designed to accept pedestrian foot traffic associated with normal maintenance operations. For regular balcony or walkway foot traffic an alternative system will be required. Please contact Polyroof Products Limited Technical Department for details. Further useful information in relation to the Protec Evolve System is available from the following website links:

- Literature and third-party accreditations: <https://polyroof.co.uk/products/protec-evolve/>
- Guarantees: <http://polyroof.co.uk/about/polyroof-guarantees/>

PROTEC EVOLVE SYSTEM WARM ROOF NEW BUILD (POLYROOF SA CARRIER LAYER) GUIDANCE DOCUMENT

Polyroof.co.uk
0800 801 890

2 Specification Summary

2.1 Construction A – Timber Joists

2.1.1 Overview

The following drawing of the proposed roof construction is indicative only. Please note that perimeter edge detailing may vary.

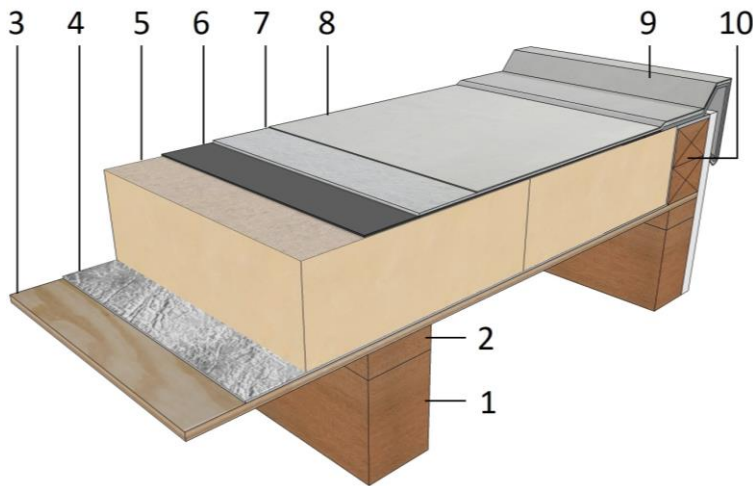

Important - No deviation to the proposed construction or substitution of materials will be permitted unless advanced approval is obtained from Polyroof Products Technical Services.

1. Timber joists at 400mm centres
2. Timber furrings (min. 1 in 80 finished fall)
3. 18mm Plywood / OSB3 spreadsheet – primed with Polyroof SA Primer
4. Polyroof SA Vapour Barrier
5. Polyroof Tissue-Therm Insulation – bonded using Polyroof Single Pack Insulation Adhesive
6. Polyroof SA Carrier Layer
7. 1st Coat Protec Evolve Resin (Cirrus Light Grey) and Polymat 450 reinforcement
8. 2nd Coat Protec Evolve Resin (Cirrus Light Grey or Nimbus Dark Grey)
9. Pre-formed Polyroof GRP upstand trim
10. Timber hard edge

It is recommended that wind uplift calculations are carried out prior to undertaking any roofing project to ensure that the adhesive and / or mechanical fixings meet the required performance. Please contact Polyroof Technical Services for further guidance.

PROTEC EVOLVE SYSTEM WARM ROOF NEW BUILD (POLYROOF SA CARRIER LAYER) GUIDANCE DOCUMENT

Polyroof.co.uk
0800 801 890

2.1.2 Timber Joists - Construction Notes

2.1.2.1 Preparation

For specific guidance on preparation of substrates please refer to the Protec Evolve Manual issued by Polyroof Technical Services.

2.1.2.2 Falls & Drainage

Timber Firrings – Where required firrings are to be installed to create a minimum finished 1 in 80 fall using proprietary fixings applicable to the construction and environmental conditions.

NB: Although standing water is not detrimental to the Protec Evolve System it could be hazardous to foot traffic in icy conditions. An alternative specification for Polyroof Cut-to-Falls Insulation is also available upon request from Polyroof Technical Services. It has been assumed that the proposed drainage capacity is adequate.

2.1.2.3 Plywood / OSB3 Spreadsheet

An 18mm plywood / OSB3 spreadsheet is to be mechanically fixed to the timber joists.

Plywood / OSB3 Spreadsheet to Timber Joists	
Fixing Type	EJOT TKR Range
Minimum Penetration into Timber Joists	40 mm
Minimum Fixings per Board (Plywood)	24 Nr (2400mm x 1200mm board)
Minimum Fixings per Board (OSB3)	20 Nr (2400mm x 600mm board)

For installation of the timber hard edge, air and vapour control layer (AVCL), insulation and Protec Evolve System refer to Sections 2.4 and 2.5.

PROTEC EVOLVE SYSTEM WARM ROOF NEW BUILD (POLYROOF SA CARRIER LAYER) GUIDANCE DOCUMENT

Polyroof.co.uk
0800 801 890

2.2 Construction B – Concrete Decks

2.2.1 Overview

The following drawing of the proposed roof construction is indicative only. Please note that perimeter edge detailing may vary.

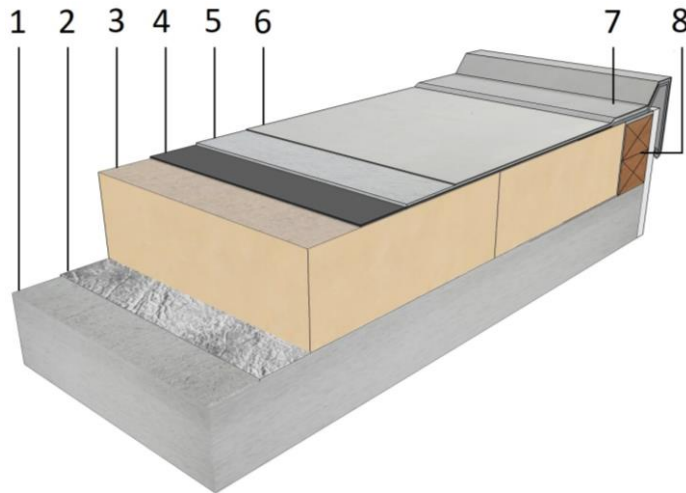

Important – No deviation to the proposed construction or substitution of materials will be permitted unless advanced approval is obtained from Polyroof Products Technical Services.

1. Concrete deck / screed (min. 1 in 80 finished fall) – primed with Polyroof SA Primer
2. Polyroof SA Vapour Barrier
3. Polyroof Tissue-Therm Insulation – bonded using Polyroof Single Pack Insulation Adhesive
4. Polyroof SA Carrier Layer
5. 1st Coat Protec Evolve Resin and Polymat 450 reinforcement
6. 2nd Coat Protec Evolve Resin
7. Pre-formed Polyroof GRP upstand trim
8. Timber hard edge

It is recommended that wind uplift calculations are carried out prior to undertaking any roofing project to ensure that the adhesive and / or mechanical fixings meet the required performance. Please contact Polyroof Technical Services for further guidance.

PROTEC EVOLVE SYSTEM WARM ROOF NEW BUILD (POLYROOF SA CARRIER LAYER) GUIDANCE DOCUMENT

Polyroof.co.uk
0800 801 890

2.2.2 Concrete Decks – Construction Notes

2.2.2.1 Preparation

For specific guidance on preparation of substrates please refer to the Protec Evolve manual issued by Polyroof Technical Services.

2.2.2.2 Falls & Drainage

Screed to Falls – Where required a screed to falls is to be laid to create a minimum finished 1 in 80 fall.

NB: Although standing water is not detrimental to the Protec Evolve System it could be hazardous to foot traffic in icy conditions. An alternative specification for Polyroof Cut-to-Falls Insulation is also available upon request from Polyroof Technical Services. It has been assumed that the proposed drainage capacity is adequate.

For installation of the timber hard edge, air and vapour control layer (AVCL), insulation and Protec Evolve System refer to Sections 2.4 and 2.5.

PROTEC EVOLVE SYSTEM WARM ROOF NEW BUILD (POLYROOF SA CARRIER LAYER) GUIDANCE DOCUMENT

Polyroof.co.uk
0800 801 890

2.3 Construction C – Structural Metal Roof Decks

2.3.1 Overview

The following drawing of the proposed roof construction is indicative only. Please note that perimeter edge detailing may vary.

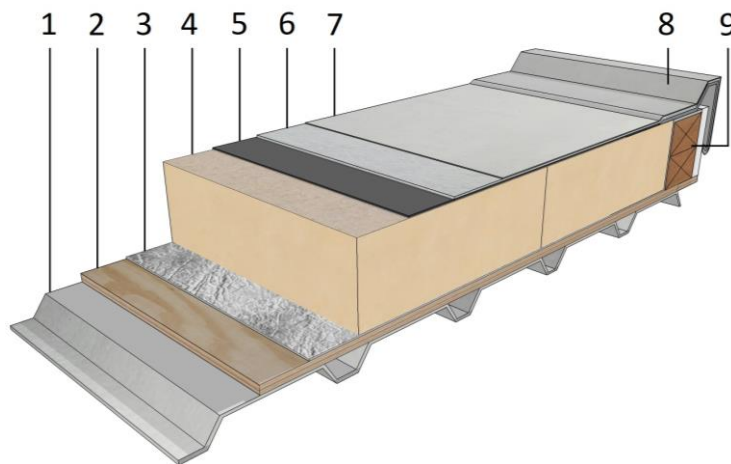

Important - No deviation to the proposed construction or substitution of materials will be permitted unless advanced approval is obtained from Polyroof Products Technical Services.

1. Structural metal roof deck (min. 1 in 80 finished fall)
2. 18mm plywood / OSB3 spreadsheet* – primed with Polyroof SA Primer
3. Polyroof SA Vapour Barrier
4. Polyroof Tissue-Therm Insulation – bonded using Polyroof Single Pack Insulation Adhesive
5. Polyroof SA Carrier Layer
6. 1st Coat Protec Evolve Resin and Polymat 450 reinforcement
7. 2nd Coat Protec Evolve Resin
8. Pre-formed Polyroof GRP upstand trim
9. Timber hard edge

*18mm plywood / OSB3 spreadsheet not necessary if the structural metal roof deck provides sufficient support for the air and vapour control layer (AVCL) and insulation. The structural metal roof deck should be fit for purpose and installed in accordance with the manufacturer's recommendations and BS6229:2018 (minimum 1:80 falls for standard flat roofs). A typical example of a suitable structural metal roof deck is the TATA RoofDek D35 (further details may be found at: www.tatasteelconstruction.com).

It is recommended that wind uplift calculations are carried out prior to undertaking any roofing project to ensure that the adhesive and / or mechanical fixings meet the required performance. Please contact Polyroof Technical Services for further guidance.

PROTEC EVOLVE SYSTEM WARM ROOF NEW BUILD (POLYROOF SA CARRIER LAYER) GUIDANCE DOCUMENT

Polyroof.co.uk
0800 801 890

2.3.2 Structural Metal Roof Decks – Construction Notes

2.3.2.1 Preparation

For specific guidance on preparation of substrates please refer to the Protec Evolve Manual issued by Polyroof Technical Services.

2.3.2.2 Falls & Drainage

Structural Metal Roof Deck to Falls – This specification assumes that the structural metal roof deck is provided with a minimum finished 1 in 80 fall.

NB: Although standing water is not detrimental to the Protec Evolve System it could be hazardous to foot traffic in icy conditions. An alternative specification for Polyroof Cut-to-Falls Insulation is also available upon request from Polyroof Technical Services.

It has been assumed that the proposed drainage capacity is adequate.

2.3.2.3 Plywood / OSB3 Spreadsheet (If required)*

An 18mm plywood / OSB3 spreadsheet is to be mechanically fixed to the structural metal roof deck (if required).

Plywood / OSB3 Spreadsheet to Structural Metal Roof Deck	
Fixing Type	EJOT TKR Range
Min. Penetration into Structural Metal Roof Deck	20 mm
Minimum Fixings per Board (Plywood)	24 Nr (2400mm x 1200mm board)
Minimum Fixings per Board (OSB3)	20 Nr (2400mm x 600mm board)

*Note - The spreadsheet is not necessary if the structural metal roof deck provides sufficient support for the air and vapour carrier layer (AVCL) and insulation. Consult Polyroof Technical Services for advice.

For installation of the timber hard edge, air and vapour control layer (AVCL), insulation and Protec Evolve System refer to Sections 2.4 and 2.5.

PROTECEVOLVE SYSTEM WARM ROOF NEW BUILD (POLYROOF SA CARRIER LAYER) GUIDANCE DOCUMENT

Polyroof.co.uk
0800 801 890

2.4 Warm Roof Components

Please refer to Section 5 for the Technical Datasheets of the products described below.

2.4.1 Timber Hard Edge

A timber hard edge must be fitted to all exposed perimeter edges of the roof at 300-400mm centres into the timber joists / concrete deck / structural metal roof deck using screw fixings applicable to the construction and environmental conditions. The hard edge may be built-up using sections of suitably sized timber as required. **IMPORTANT:** Screw fixings must be used at all times.

Timber Hard Edge to Timber Joists / Structural Metal Roof Deck	
Fixing Type	EJOT TKR Range
Min Penetration	40mm (Timber Joists) 20mm (Structural Metal Deck)
Fixing Centres	300-400mm

NB: Ensure fixings hit every joist and use intermediate fixings to the spreadsheet if joist centres exceed 400mm.

Timber Hard Edge to Concrete Deck	
Fixing Type	EJOT FBS-R Range
Min Penetration into Concrete Deck	30mm
Pilot Hole	5.0mm diameter
Fixing Centres	300-400mm

NB: Pull-out failure tests will be required to confirm the correct fixing type and length when fixing into a concrete deck. Please contact Polyroof Products Ltd Technical Services for further details.

Important Notes:

- Please consult Polyroof Technical Services for guidance on fixing the timber hard edge to any other type of support structure.
- Always calculate screw fixing requirements in accordance with BS6399-2:1997 and never use less than 1 fixing per 400mm under any circumstances.
- All fixings must be capable of withstanding necessary wind uplift pressures and environmental conditions in accordance with BS 6399-2:1997.

2.4.2 Air & Vapour Control Layer (AVCL)

Prior to laying the new Polyroof SA Vapour Barrier surfaces should be smooth and level without voids, sharp protrusions, tension or blisters. They should also be clean, dry and free from dust, frost or dew.

Prime surfaces as required with Polyroof SA Primer. A self-adhesive Polyroof SA Vapour Barrier is then to be applied to the roof deck and fitted strictly in accordance with

PROTECEVOLVE SYSTEM WARM ROOF NEW BUILD (POLYROOF SA CARRIER LAYER) GUIDANCE DOCUMENT

Polyroof.co.uk
0800 801 890

manufacturer's recommendations. The AVCL shall be continuous and encapsulate the insulation boards at abutments, penetrations and exposed edges.

NB: For options on cold-applied felt AVCLs contact Polyroof technical services.

2.4.3 Polyroof Tissue-Therm Insulation

Polyroof Tissue-Therm Insulation is to be bonded using Polyroof Single Pack Insulation Adhesive* applied strictly in accordance with the manufacturer's recommendations.

*Adhesive must be capable of withstanding necessary wind uplift pressures and environmental conditions. Always calculate bonding requirements in accordance with BS 6399-2:1997.

Notes:

- Polyroof Tissue-Therm Insulation is to be laid staggered (brick pattern).
- Sufficient Polyroof Single Pack Insulation Adhesive should be provided to bond the two separate layers of insulation when installing two-layer designs.
- The warm roof construction should be suitably protected during the construction phase to avoid excessive moisture within the construction.
- If temporary protection fails and the roof construction becomes wet then advice should be sought from Polyroof Products Ltd Technical Services with regards to the requirement for temporary roof vents.

2.4.4 Polyroof Single Pack Insulation Adhesive Guidance

Important - Wind uplift calculations are recommended prior to undertaking any roofing project to ensure that the adhesive meets the required performance. Always calculate bonding requirements in accordance with BS 6399-2:1997.

Adhesive Application Rates

Apply adhesive 20-40mm Bead Size in accordance with the following application centres; Leave the beads exposed for 3 – 5 minutes to ensure they form enough body before the boards are laid into the adhesive.

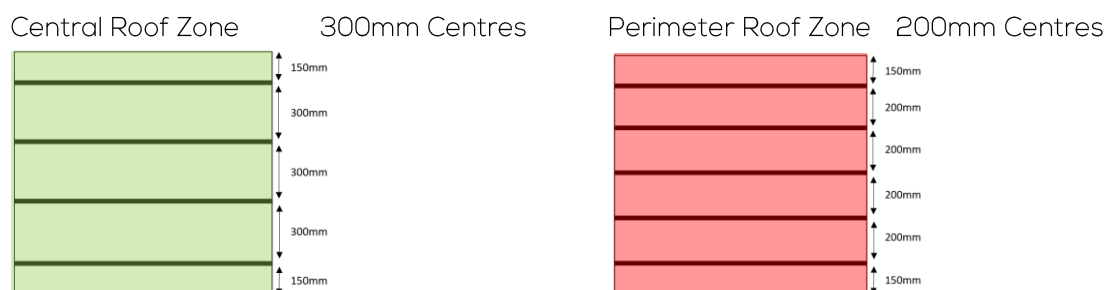

Please note that the above is the absolute minimum requirement and is indicative only.

PROTECEVOLVE SYSTEM WARM ROOF NEW BUILD (POLYROOF SA CARRIER LAYER) GUIDANCE DOCUMENT

Polyroof.co.uk
0800 801 890

Roof Plan / Roof Zones (Indicative Plan)

Central and perimeter zones, and their associated widths, should be determined by project specific wind uplift calculations. The following guidance is indicative. The perimeter zone must be at least a 2m zone as an absolute minimum, however wind uplift calculations will confirm.

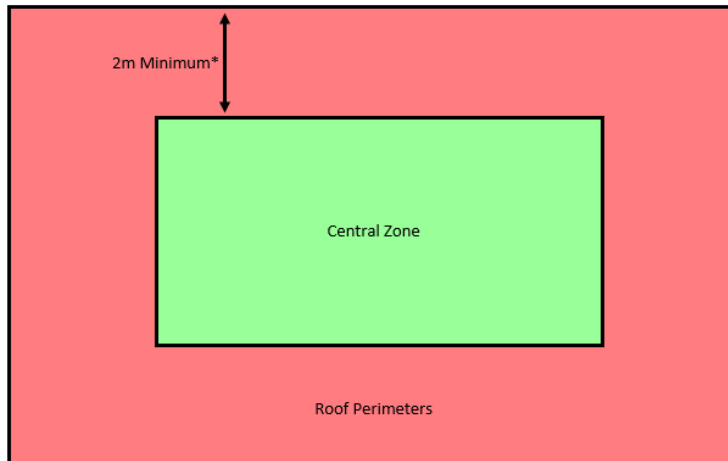

*Indicative only.

Always ensure a minimum 2m wide perimeter zone as an absolute minimum.

NB: Please note the option to dual fix (mechanically fix and adhesively bond) is available. Please contact Polyroof Technical Services should you require any further information.

2.4.5 Fillet Details

50mm x 50mm Polyroof Tissue-Therm insulated fillets are to be installed at all right-angled junctions.

2.4.6 Polyroof SA Carrier Layer

Prime Polyroof Tissue-Therm Insulation with Polyroof SA Primer. A self-adhesive Polyroof SA Carrier Layer is then to be applied to the insulation and fitted strictly in accordance with manufacturer's recommendations.

2.4.7 Warm Roof – Other Notes

- It is the client's responsibility to confirm the required U-value based on performance requirements and current building regulations standards. If in any doubt further guidance should be sought from local authority building control regarding this.
- For U-Value options and corresponding insulation thicknesses please refer to the Protec System Thermal Performance Guidance Sheet.

PROTEC EVOLVE SYSTEM WARM ROOF NEW BUILD (POLYROOF SA CARRIER LAYER) GUIDANCE DOCUMENT

Polyroof.co.uk
0800 801 890

2.5 Protec Evolve Application

2.5.1 Overview

Protec Evolve is a flexible, cold liquid applied, seamless polyester methacrylate waterproofing system which is ideally suited for long term waterproofing of flat roofs. The system has low-odour making it the ideal waterproofing system for sensitive areas such as the refurbishment of schools and hospitals. The system should be applied in accordance with the current application manual issued by Polyroof Products Limited.

2.5.2 Approved Contractors

Protec Evolve should only be applied by contractors in possession of a current approval certificate. The contractor must provide an approved applicator to supervise the Protec Evolve work and the approved applicator must remain on the site until the works are complete. Confirmation of approval can be sought by calling Polyroof Products Ltd Technical Services on +44 (0) 800 801 890. A final inspection shall be carried out by a Polyroof technician prior to a guarantee being issued.

2.5.3 Weather Considerations

The system should not be applied if the air temperature is outside the range of 2degC - 30degC (NB: The system can be installed down as low as 2degC deck temperature with the addition of Product Accelerators). The system must not be applied in damp or cold conditions which could cause surface condensation; during frost or if there is a risk of rain.

2.5.4 Pigment Colour

Protec Evolve is a 2 coat application. The product is pre-pigmented and is available in Cirrus light grey and Nimbus dark grey. The recommended colour for the first coat is Cirrus light grey for optimum application performance. The system may be finished using either Cirrus light grey or Nimbus dark grey as the second coat.

2.5.5 Primer Coat

Polyroof SA Carrier Layer – No overall primer required.

Other Surfaces – For priming of any other surfaces please refer to the Protec Evolve Manual issued by Polyroof Products Limited.

2.5.6 Detailing

Pre-formed Polyroof GRP Trims (Exposed Perimeters) – Pre-formed Polyroof GRP trims must be mechanically fixed on the horizontal fixing arm to the timber hard edge at 150mm maximum centres using approved fixings. In addition, drip or upstand trims with a face depth equal to or greater than 150mm must be mechanically fixed to the trim support batten at 300mm maximum centres using 18mm galvanized clout nails (large headed). All angles shall

PROTEC EVOLVE SYSTEM WARM ROOF NEW BUILD (POLYROOF SA CARRIER LAYER) GUIDANCE DOCUMENT

Polyroof.co.uk
0800 801 890

be mitred, and all joints should be reinforced with Protec Evolve Resin and 2 layers of 75mm wide Polymat 450. Allow to cure.

Important Notes:

- For drip or upstand trims additional support must be provided in the form of trim support battens and butt straps at the trim joints.
- On exposed sites all trims must be face fixed regardless of size.

Other Details – To any other details requiring local reinforcement apply Protec Evolve Resin and 75mm wide Polymat 450. Allow to cure. NB: Apply 25mm dis-bondment tape to any cracks or joints subject to movement prior to application of local reinforcement.

2.5.7 First Coat Application

Apply 1st coat of Protec Evolve Resin (Cirrus light grey) and Polymat 450 at a minimum coverage rate of 1.3 - 1.5Litres/m² (0.66 - 0.77m²/Litre). Allow to cure.

NB: Please note that all coverage rates are indicative only and it is the contractors' responsibility to ascertain the exact coverage rates on site.

2.5.8 Second Coat Application

Apply 2nd coat of Protec Evolve Resin (Cirrus light grey or Nimbus dark grey) at a minimum coverage rate of 0.5Litres/m² (2.0m²/Litre). Allow to cure.

2.5.9 Anti-Slip Finish (Optional)

Protec Evolve is designed to accept pedestrian foot traffic associated with normal maintenance operations; however, optional anti-slip finishes are available. Please note that for regular balcony or walkway foot traffic an alternative system will be required. Please contact Polyroof Products Limited Technical Department for details.

2.5.10 Inspection

On completion of each coat check for pinholes / misses and rectify accordingly.

2.5.11 Protection of Finished Membrane

In the event of other trades working on or adjacent to the roof area, the client must make adequate provision to prevent damage to the roofing system, by other trades. Site specifics should be discussed with the Approved Contractor.

2.5.12 Additional Items

Should the client wish to install additional items such as paving slabs or timber decking, please consult Polyroof Products Ltd Technical Services prior to the commencement of any project.

PROTEC EVOLVE SYSTEM WARM ROOF NEW BUILD (POLYROOF SA CARRIER LAYER) GUIDANCE DOCUMENT

Polyroof.co.uk
0800 801 890

Prior to the installation of additional items, the contractor should ensure that Polyroof Technical Services are contacted and given the opportunity to inspect the membrane before it is covered. Please note that should an inspection of the Protec Evolve System ever be required in the future it would be the client's responsibility to remove the additional items back to the membrane.

PROTEC EVOLVE SYSTEM WARM ROOF NEW BUILD (POLYROOF SA CARRIER LAYER) GUIDANCE DOCUMENT

Polyroof.co.uk
0800 801 890

2.6 Roof Details

Please note site investigation may be required to identify all roof details and to determine the required action to ensure they are left in a fully watertight condition. A range of CAD details are available for download from: <http://polyroof.co.uk/products/protac-system/>

Detailing Notes:

- Roof termination details should have a minimum 150mm upstand height above the finished surface of the roof and should be terminated into a chase or have a suitable cover flashing or weathering flange. Any details where this cannot be achieved will require periodic inspection and maintenance.
- Care should be taken to ensure all roof details are fully prepared and primed in accordance with the Protec Evolve Manual.

PROTEC EVOLVE SYSTEM WARM ROOF NEW BUILD (POLYROOF SA CARRIER LAYER) GUIDANCE DOCUMENT

Polyroof.co.uk
0800 801 890

3 NBS Clauses (Uniclass)

The following are indicative only and should be read in conjunction with the outline specification in Section 2. For a details NBS Specification, please contact Polyroof Technical Servicers on +44 (0) 800 801 890

Ss_30_40_30_43

Liquid-applied warm roof covering systems

Systems

Ss_30_40_30_43 Liquid-applied warm roof covering systems

1. Description: Protec Evolve Warm Roof New Build (Carrier Layer)
2. System manufacturer: **Polyroof Products Ltd**
3. Contact details
 - 3.1. Address: Furness House
Castle Park Industrial Estate
Flint
Flintshire
United Kingdom
CH6 5XA
 - 3.2. Telephone: **+44 (0)1352 735135**
 - 3.3. Web: **www.polyroof.co.uk**
 - 3.4. Email: **technical@polyroof.co.uk**
4. Product reference: **Protec Evolve Warm Roof System (Warm Roof PIR (New Build))**
5. Preparation
 - 5.1. Horizontal work: Please consult Polyroof for guidance and insert requirements
 - 5.2. Skirtings and vertical work: Please consult Polyroof for guidance and insert requirements
6. Air and vapour control layer: Polyroof SA Vapour Control Layer.
7. Insulation
 - 7.1. Type: Polyroof Tissue Therm Insulation.
(Thickness Dependent on Target U Value)
 - 7.2. Fixing: Adhesively Bonded / Mechanically Fixed. Dependant upon Wind Loading Calculation Data (BS EN 1991 – 1-4:2005 (Eurocode 1)).
8. Carrier membrane
 - 8.1. Type: Polyroof SA Carrier Layer.
9. Liquid-applied waterproofing
 - 9.1. Type: Cold liquid-applied Protec Evolve resin with catalyst (two coats).
Protec Evolve first coat application: 1.3 - 1.5 Litres/m². Protec Evolve second coat application: 0.5 Litres/m².
 - 9.2. Reinforcement: Polymat 450 (first coat).
 - 9.3. Surface treatment (Optional): Paving (with pedestals). Decking (with pedestals). Polyroof Anti-slip.
10. System accessories (Optional): Polyroof pre-formed GRP Trims. Polyroof pre-formed Internal Outlets. Polyroof pre-formed Through Wall Outlets. Polyroof Insulation Adhesive. Polyroof Fall Arrest Systems.

PROTEC EVOLVE SYSTEM WARM ROOF NEW BUILD (POLYROOF SA CARRIER LAYER) GUIDANCE DOCUMENT

Polyroof.co.uk
0800 801 890

Polyroof SA Lightning Conductor Clips. Polyroof Fixing Plates (for PV cells / Balustrade systems). Polyroof PR Rooflights. Fixings - EJOT TKR, associated stress plates and plastic tube washers. Fixings - EJOT TKE, associated stress plates and plastic tube washers. Fixings - EJOT FBS, associated stress plates and plastic tube washers. Fixings - EJOT FPS, associated stress plates and plastic tube washers.

11. Colour: Cirrus Light Grey. Nimbus Dark Grey.
12. Fire performance: Achieves Broof T4 classification in accordance with BBA certificate 09/4676.
13. Cure time: 30–60 minutes.
14. Application temperature: 2–30°C. Product Accelerators must be used between 2-7°C deck temperature
15. Substrate: Concrete. Timber. Structural metal roof deck.
16. Fall: Falls to be provided in accordance with BS6229 with a design fall of 1 in 40 to provide a finished fall of 1 in 80.
17. Certification: BBA certificate number 09/4676.
18. Slip resistance: Tested to BS 7976-2: 2002.
19. Resistance to water penetration: Suitable for use with zero falls in accordance with BBA certificate 09/4676.
20. Waterproofing: Protec Evolve cold liquid-applied membrane.
21. Installation: Installation by Polyroof-approved contractors.

PROTEC EVOLVE SYSTEM WARM ROOF NEW BUILD (POLYROOF SA CARRIER LAYER) GUIDANCE DOCUMENT

Polyroof.co.uk
0800 801 890

4 Health & Safety

4.1 Personal Protective Equipment (PPE)

Should be worn at all times. Refer to Material Safety Data Sheets for advice.

In addition to PPE, barrier cream and hand cleaner may be used for secondary protection and cleaning of exposed areas of skin.

4.2 Material Safety Data Sheets (MSDS)

It is your responsibility to ensure that all relevant MSDS documents are on site at all times. MSDS documents are provided with your first order; additional copies of these sheets are available on request from Polyroof Technical Services. You can download the current versions from the Polyroof Approved Contractor Zone.

4.3 Risk Assessments / Method Statements

It is the responsibility of the contractor to ensure that adequate risk assessments (including COSHH assessments) and method statements are carried out prior to commencement of works.

4.4 VOC / Odour Control

Most products contain volatile components, such as solvents; these components evaporate from the system during and post application. Some of the volatiles within certain products have a strong odour and others such as within our Protec Evolve system have a low odour. Some volatiles require hazard control measures, and these are stated on the MSDS sheets. Some hazardous VOCs (Volatile Organic Content) are assigned a 'Workplace Exposure Limit' (WEL): the legal maximum concentration in the air that an individual may be exposed to within a prescribed period of time. Some of these hazardous materials have also been assigned a 'Derived No Effect Level' (DNEL). Historic tests carried out on typical flat roofs indicate that neither the operatives fitting the system nor people within or in the vicinity of the building to which the system is applied, will be exposed to concentrations in excess of the WELs, the actual concentrations will be significantly lower.

It should be borne in mind that, whilst some of these VOCs have a strong odour and can be detected at low concentrations, the fact that they can be smelt does not mean individuals are exposed to hazardous levels.

The contractor carrying out the work is obliged to carry out a risk assessment and ensure sensible precautions are taken, such precautions would include checking the isolation of air intakes to the building and ensuring the avoidance of working within confined spaces: both could otherwise increase the exposure levels beyond those of our testing. It should also be noted that a low odour product such as Protec Evolve has a lower level of malodorous VOC's and this does not eliminate the need for a risk assessment.

PROTECEVOLVE SYSTEM WARM ROOF NEW BUILD (POLYROOF SA CARRIER LAYER) GUIDANCE DOCUMENT

Polyroof.co.uk
0800 801 890

To assure the occupants of the building, who may be concerned about an unfamiliar smell, warn them of the likelihood before work commences.

4.5 VOC Measuring

In sensitive areas it is usually possible to monitor the atmosphere for levels of VOC's, and potentially hazardous fumes by using specialist testing equipment. With most products portable site testing equipment may be used that will give an immediate indication of the concentration of specific solvents in the atmosphere. This can show that the appropriate WEL or DNEL, is not being exceeded. In rare circumstances the services of specialist industrial hygiene companies may be required.

The contractor's risk and COSHH assessments should identify if there is a need for atmospheric monitoring.

PROTEC EVOLVE SYSTEM WARM ROOF NEW BUILD (POLYROOF SA CARRIER LAYER) GUIDANCE DOCUMENT

Polyroof.co.uk
0800 801 890

5 Further Information

5.1 Warm Roof Components

Please click on the following website link to access the Technical Datasheets of the products listed below: <https://polyroof.co.uk/resources/technical-data-sheets/>

- Polyroof SA Primer
- Polyroof SA Vapour Barrier
- Polyroof Single Pack Insulation Adhesive
- Polyroof Tissue-Therm Insulation*

*This tab also includes the Protec System Thermal Performance Guidance Sheet which provides options on insulation thicknesses and corresponding U-Values.

5.2 Further Reading

The following is a list of documents which provide further information in relation to the guidance provided in this outline specification:

- Protec Evolve Manual
- EJOT Building Fastener Catalogue

Please contact Polyroof Technical Services on +44 (0) 800 801 890 to request copies of the above or for further guidance.

• ADVISE • DESIGN •
GUARANTEE • SUPPORT •

POLYROOF
ADVANCED LIQUID ROOFING

Part of
**Roberts
Group**